

# Door & Hinge for Left Side Door

Please read through these instructions before beginning.

This guide will walk you through switching the opening direction of you on bench pantry from right opening to left opening.

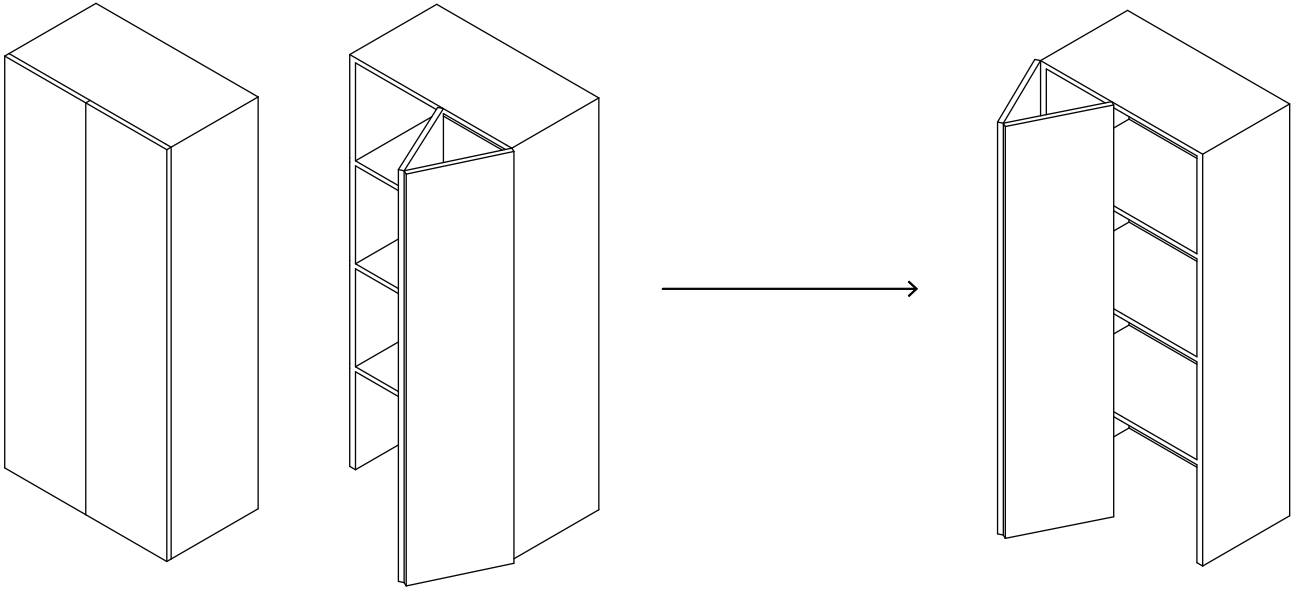

## Step 1

Rotate your doors 180° so that they are orientated as shown.

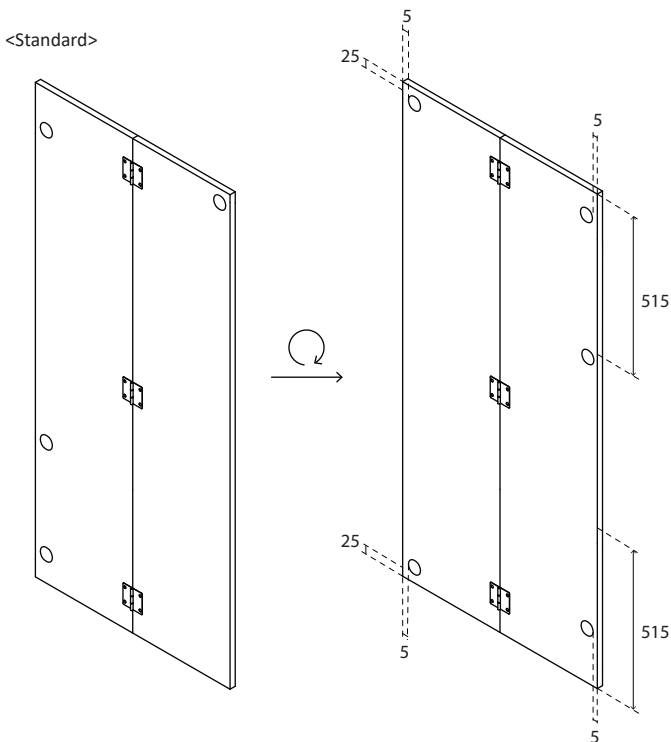

## Step 2

You will need to drill a new hole for the middle hinge. Ensure that it is the same distance from the top and outside edge as the original one.

Drill out new hole for a hinge to body

<From the bottom>

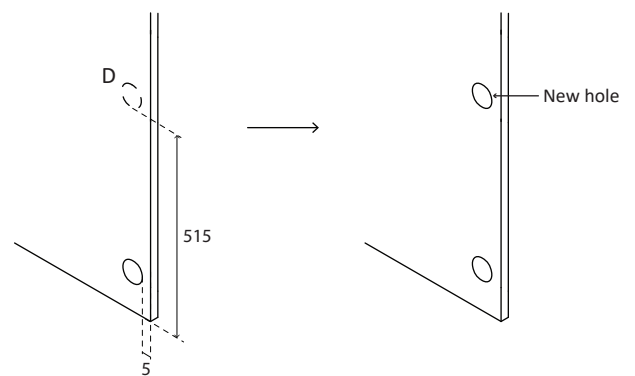

Drill out new hole for a tracking hinge

<From the bottom>

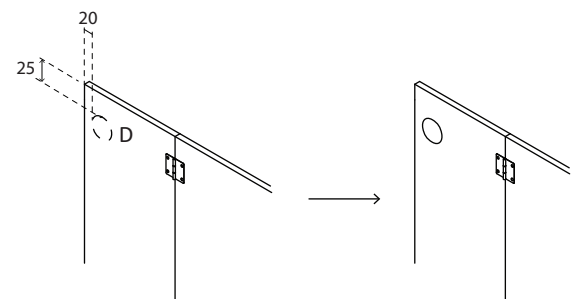

### Step 3

Remove the runner unit from the tracking hinge(B0 in the assembly instructions) by removing the screw in the side. Flip the hinge over so that it is facing the left, as shown below. Re-attach the runner unit by screwing through the left side.

<Standard>

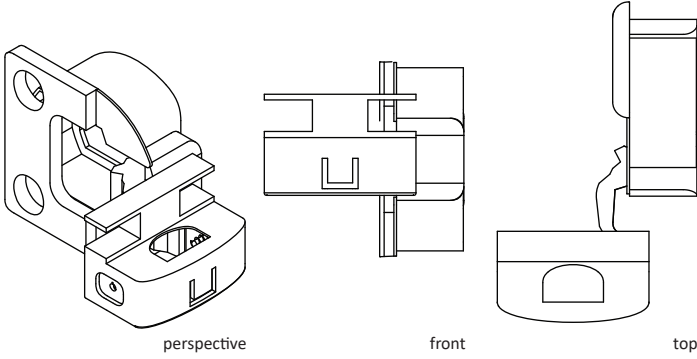

1. Unscrew the screw from right side of the tracking hinge.

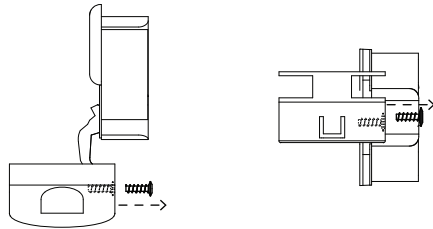

2. Separate the tracking hinge, as shown below.

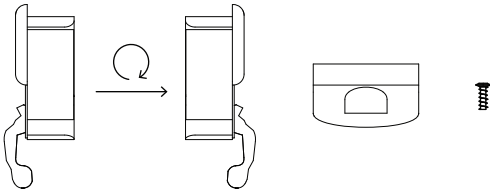

3. Screw the screw on the left side of the tracking hinge.

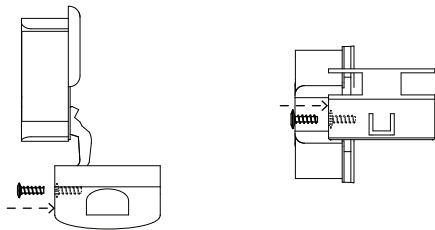

<Final>

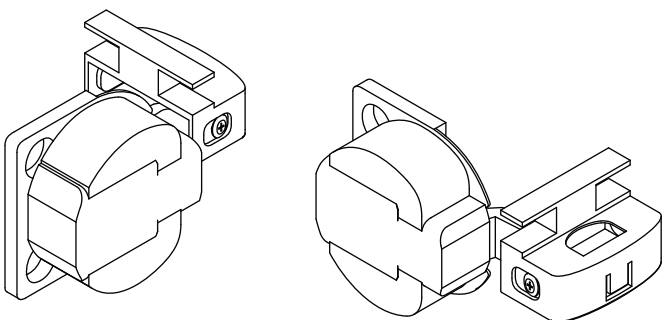

### Step 4

Attach hinges and mount the door on the cabinet. The door should look like the image below.

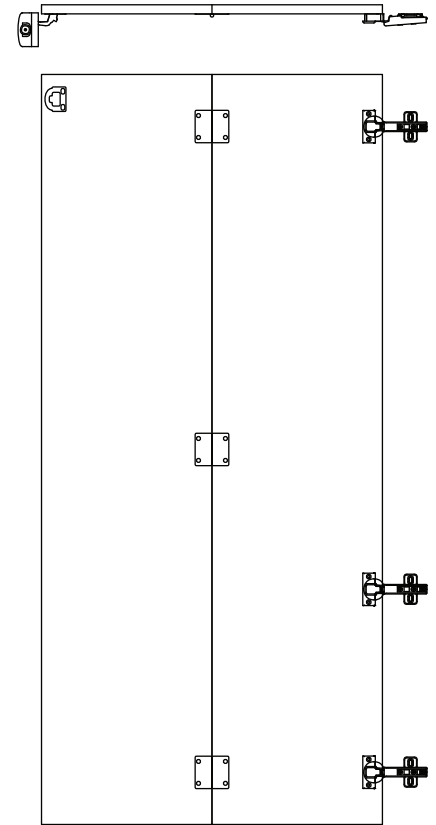

### Step 5

Pull the locking pin into the down position. It is located at the base of the runner unit. Open the door to its widest, then push the locking pin to the up position.

